



Specifications

Maximum working pressure : 10 bar
 (6bar for CDA 1.00)
 Maximum liquid temperature: 90°C
 (40°C for CDA 1.00)

Materials

Pump casing: Cast Iron
 Impeller: Brass, (Noryl for CDA 1.00)
 Shaft : AISI 303, (AISI 416 for CDA 1.00)
 Bracket: Cast Iron, (Aluminium for CDA 1.00)
 Mechanical seal: Carbon/Ceramic/NBR

Technical Data

TEFC, 2 pole motor
 Insulation class F
 IP44 protection
 1Ø, 240 Volt, 50 Hz
 Permanent split capacitor
 Automatic thermal overload protection

Twin Impeller centrifugal pumps manufactured in cast iron. Suitable for boosting or transfer of water, washdown, small scale irrigation, etc.

Performance Curve

Synchronous Speed:
 3000 r.p.m.

Water temp:
 20°C

Applicable standard of test :
 ISO 2458
 Class C

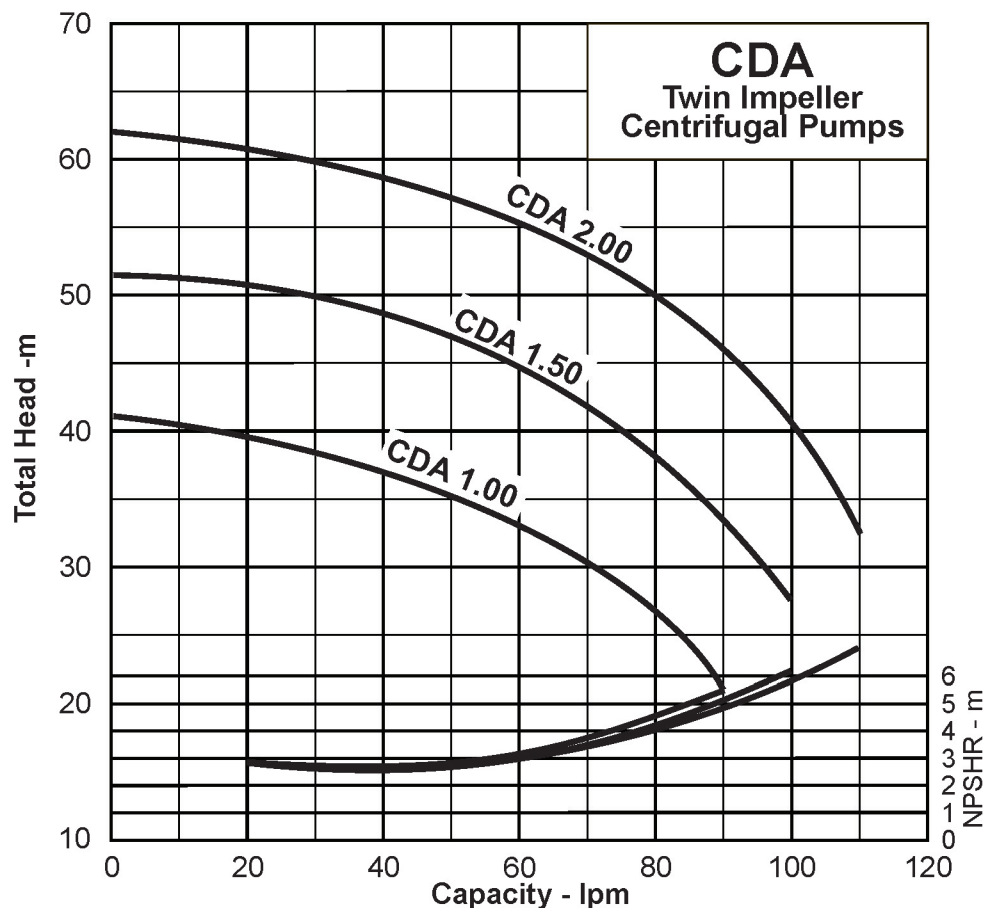

Model Code

CDA 1.50 M
 M= Single Phase
 Motor Size (HP)
 Model CDA

Performance Table

Pump Model	Motor Output	Power Supply	Capacitor		Full Load Current	Q= Capacity - litres/min									
			µF	Vc		20	40	50	80	90	100	110			
CDA 1.00 M	0.75 kW	240 V, 1ph.	20 µF	450 Vc	6.1 A	39.5	37	35.2	27						
CDA 1.50 M	1.1 kW	240 V, 1ph.	35 µF	450 Vc	8.6 A	50.8	48.8	47.1	38.4	33.4	27.5				
CDA 2.00 M	1.5 kW	240 V, 1ph.	40 µF	450 Vc	10.8 A	60.5	58.6	56.9	49.8	46.5	40.3	32.5			

Sectional Drawing

Model CDA

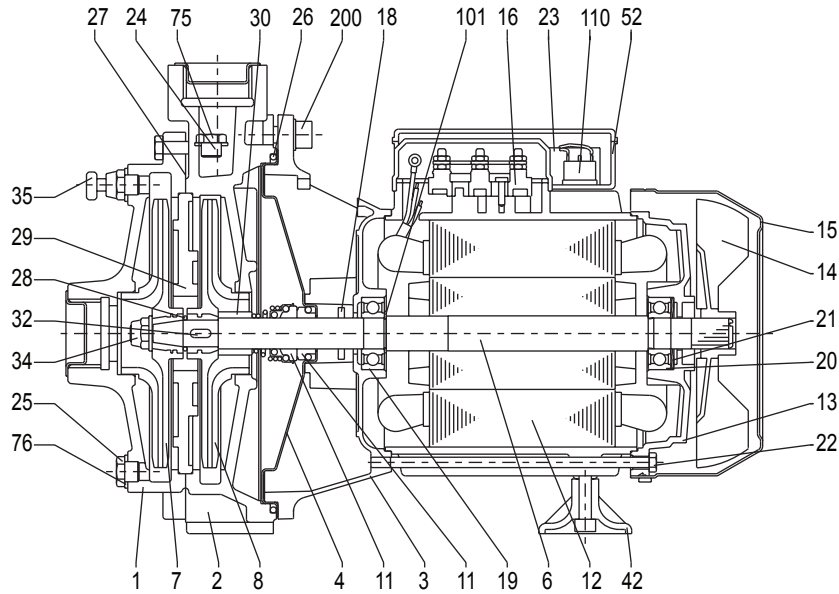

No.	Part name	Material			Qty	No.	Part name	Material			Qty	No.	Part name	Material			Qty
		CDA 1.00M	CDA 1.50M	CDA 2.00M				CDA 1.00M	CDA 1.50M	CDA 2.00M				CDA 1.00M	CDA 1.50M	CDA 2.00M	
1	Casing	Cast Iron			1	16	Terminal block	-			1	29	Intermediate plate	Cast Iron			1
2	Casing	Cast Iron			1	18	Splash ring	NBR			1	30	Mech. Seal spacer	Brass			1
3	Motor Bracket	Alum	Cast Iron		1	19	Pump side bearing	Sealed ball			1	32	Key	AISI 304			1
4	Casing Cover	AISI 304	Cast Iron		1	20	Fan side bearing	Sealed ball			1	34	Impeller nut	AISI 304			1
6	Shaft with rotor	AISI 416	AISI 303		1	21	Adjusting ring	Steel C70			1	35	Air breather valve	-			1
7	Impeller	Noryl	Brass		1	22	Tie rod	Fe 42 Zincd			4	42	Foot	PVC			1
8	Impeller	Noryl	Brass		1	23	Capacitor	-			1	52	Terminal box	Polypropylene			1
11	Mechanical Seal	Car/Cer/NBR			1	24	Priming plug	Brass			1	75	Washer	Aluminium			1
12	Motor frame & stator	-			1	25	Drain plug	Brass			1	76	Washer	Aluminium			1
13	Motor Cover	Aluminium			1	26	O-ring	NBR			1	101	Seeger ring	AISI 420			1
14	Fan	Polypropylene			1	27	Gasket	Fibre			1	110	Protector	-			1
15	Fan Cover	Fe P04 Zincd			1	28	O-ring	NBR			1	200	Screw	S Steel			4

Dimensions

Model CDA

Units: mm unless otherwise specified

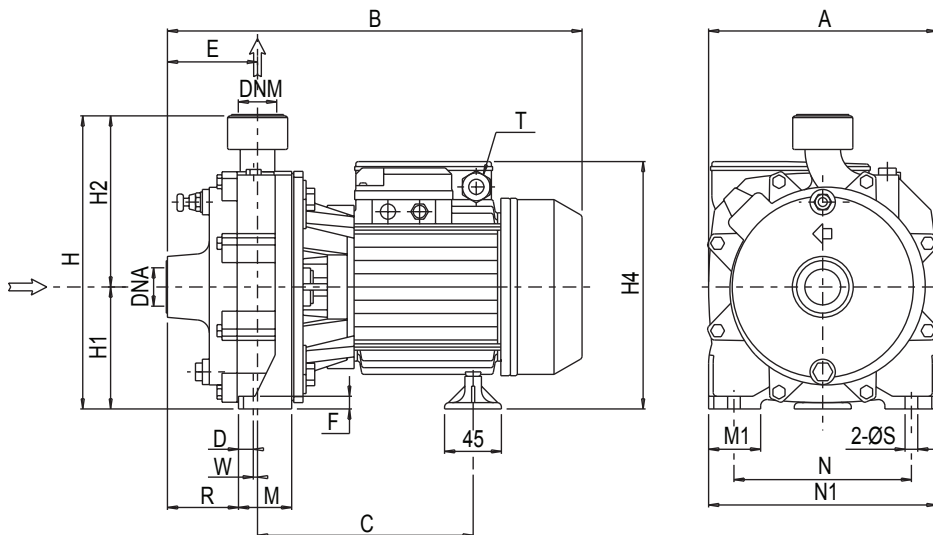

	A	B	C	D	E	F	H	H1	H2	H4	M	M1	N	N1	R	T	W	S	DNA	DNM	Weight
CDA 1.00 M	183	336.3	179.8	8.3	73	9	227	97	130	198	42	40	140	180	57.5	PG11	6.8	9.5	1"	1"	15 kg
CDA 1.50 M	209	394.8	218.3	8.3	86	9	265	110	155	242	48	40	155	195	65.5	PG13.5	12.3	9.5	1 1/4"	1"	25 kg
CDA 2.00 M	209	410.8	218.3	8.3	86	9	265	110	155	242	48	40	155	195	65.5	PG13.5	12.3	9.5	1 1/4"	1"	27 kg

Specifications subject to change without notice



EBARA PUMPS AUSTRALIA PTY. LTD.

Data Sheet

CDA 09-12m