

Stub shaft design

Uses IEC standard motors



Standard with high quality Silicon Carbide mechanical seal

All the hydraulic and wetted components are manufactured in 316 Stainless Steel

This series of stainless steel pumps feature a unique one piece volute casing that is produced using an advanced computer controlled Plasma stamping system that ensures total quality control during manufacture. With the smooth surfaces of stamped stainless steel, this results in consistent high standard products, of superior quality and high efficiency. (Cast casing on 65-250 & 80 models)

The back pull-out construction permits the disassembly and overhaul of the impeller, mechanical seal and motor without removal of the suction or discharge piping, or pump casing.

The centre line discharge and foot support under the casing ensure maximum resistance to misalignment and distortion from pipe loads.



Precision cast casing on 65-250 & 80 models

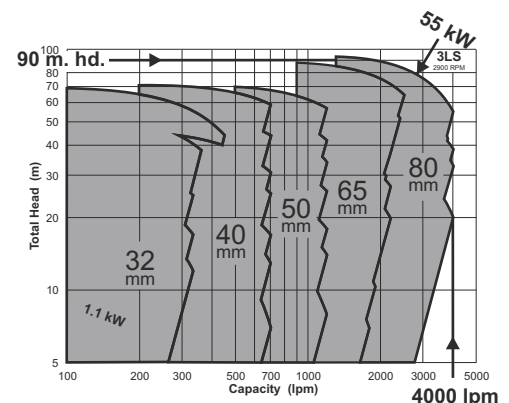

Available as pump end kit (without motor)

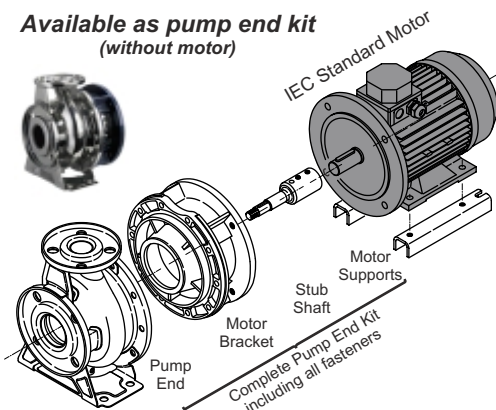

Standard IEC motors used, allowing for single phase, special enclosure, or specific brand motors to be fitted.

Specifications

- Stainless steel pump with closed impeller
- Maximum working pressure : 10 bar
- Liquid temperature: -10°C to +110°C

Materials

- Pump casing: 316 Stainless Steel
- Impeller: 316 Stainless Steel
- Casing cover: 316 Stainless Steel
- Shaft : 316 Stainless Steel
- Motor bracket: Cast Iron
- Mech. seal: Silicon Carbide/Silicon Carbide/Viton

Motor Data

- IEC standard 2 pole 50 Hz motors
- Normally fitted with WEG motors
- 3 phase, TEFC, IP55, Class F

Range

- 1.1 to 55 kW - 3 phase
- 32mm Ø to 80mm Ø discharge

Options

- Available as pump end kit without motor
- Single Phase motors
- Other motor brands, types, etc. on request.

- Over 40 model sizes
- 32mm to 80mm discharge
- 1.1 to 55 kW motor power
- Flows to 4000 lpm
- Heads to 90 metres

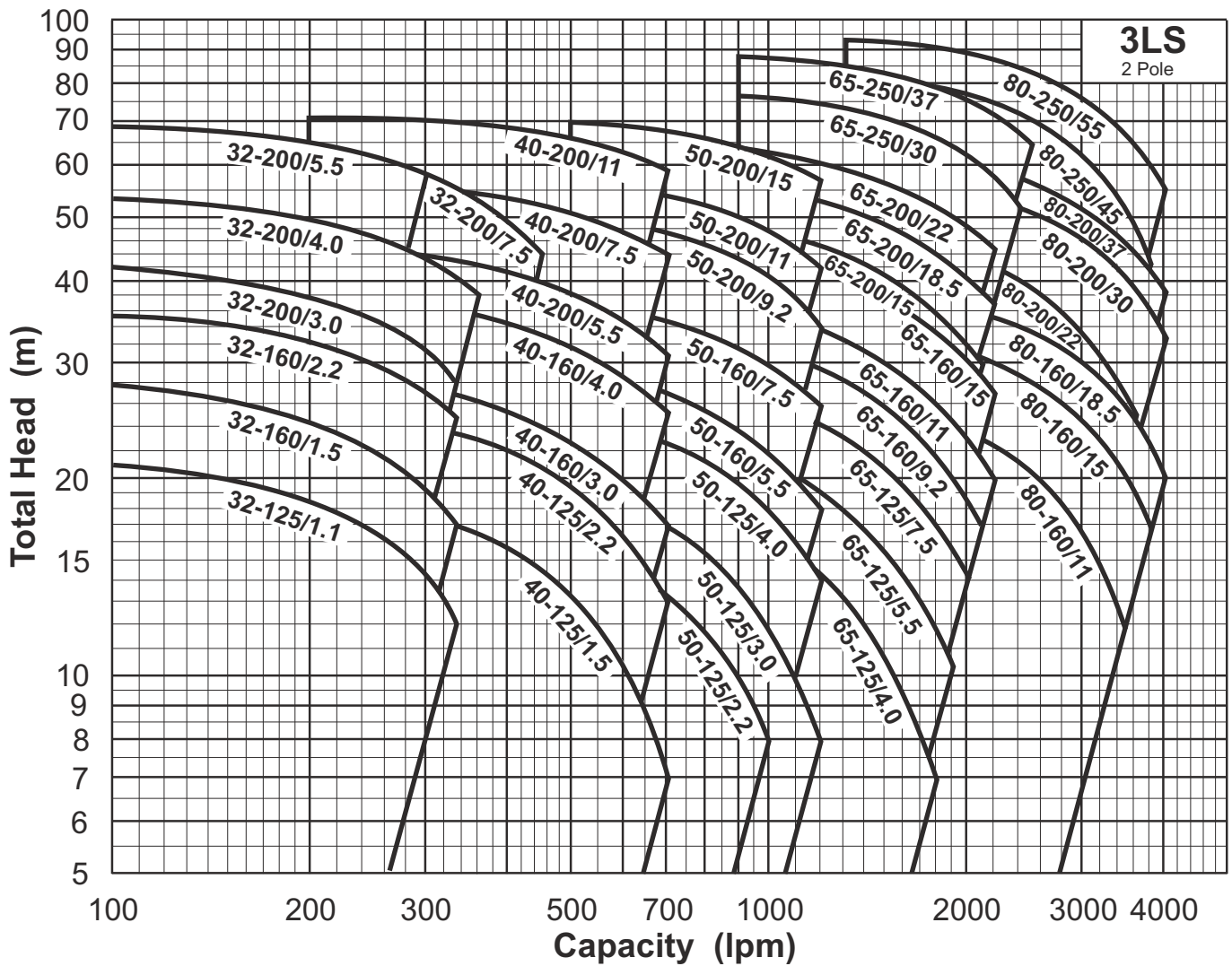

Model Code

3LS 40 - 200 / 7.5 M
 M = Single Phase
 Motor Size kW
 Nominal Impeller Diameter mm
 Discharge Size Ømm
 Model; 3LS with motor; 3LSF without motor (kit)

Synchronous Speed:
3000 r.p.m.
 Water temp:
20°C

Applicable standard of test :
ISO 2458 Class C

Configuration

3LS pumps use IEC standard motors. 3 phase WEG cast iron motors are generally fitted as standard, but single phase, specific brands, special enclosures, etc. can also be supplied. The requirements for frame size and mounting are in the dimension table. Note that B5 = Flange mount; B35 = Foot & Flange mount.

The style of motor support varies depending on model and motor size, as shown in the figures below and referred to in the dimension table.

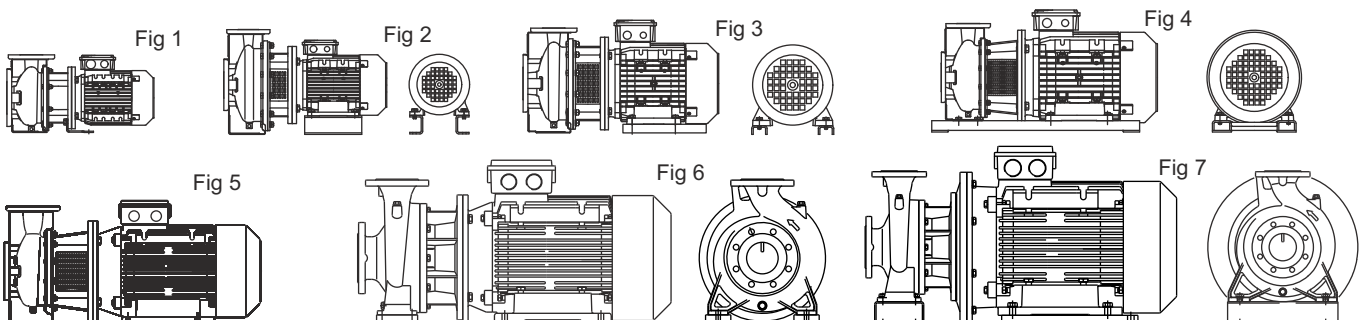

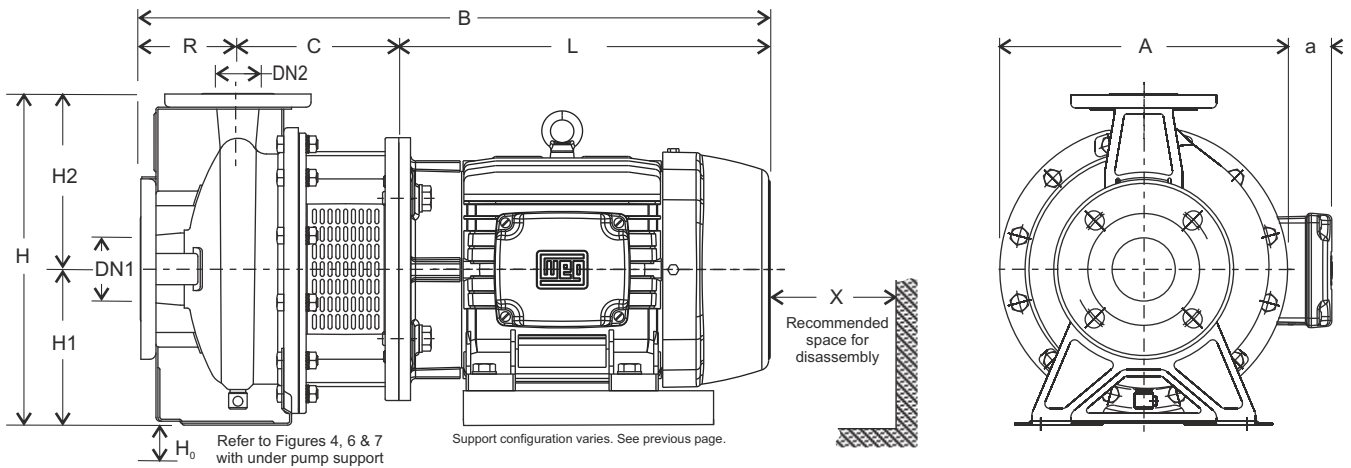

Dimensions & weights refer to units fitted with standard 3 phase cast iron WEG motors

DN2 x DN1	Pump Model (...../kW)	Motor details			Dimensions (mm)											Weight (kg)		
		Frame	Mount	Config.	H1	H2	H	H ₀	R	C	L	B	A	a	X	Pump End	Motor	Total
32 mm x 50 mm	3LS 32-125/1.1	80	B5	Fig 1	112	140	252	-	80	118	236	434	213	30	110	13	15	28
	3LS 32-160/1.5	90S	B5	Fig 1	132	160	292	-	80	130	254	464	254	28	110	17	20	37
	3LS 32-160/2.2	90L	B5	Fig 1	132	160	292	-	80	130	279	489	254	28	110	17	23	40
	3LS 32-200/3.0	100L	B35	Fig 2	160	180	340	-	80	142	316	538	296	17	110	24	33	57
	3LS 32-200/4.0	112M	B35	Fig 2	160	180	340	-	80	142	333	555	296	36	110	24	42	66
	3LS 32-200/5.5	132S	B35	Fig 3	160	180	340	-	80	165	372	617	296	64	110	28	61	89
	3LS 32-200/7.5	132S	B35	Fig 3	160	180	340	-	80	165	372	617	296	64	110	28	67	95
40 mm x 65 mm	3LS 40-125/1.5	90S	B5	Fig 1	112	140	252	-	80	130	254	464	213	49	115	15	20	35
	3LS 40-125/2.2	90L	B5	Fig 1	112	140	252	-	80	130	279	489	213	49	115	15	23	48
	3LS 40-160/3.0	100L	B35	Fig 3	132	160	292	-	80	142	316	538	254	38	115	20	33	53
	3LS 40-160/4.0	112M	B35	Fig 3	132	160	292	-	80	142	333	555	254	57	115	20	42	62
	3LS 40-200/5.5	132S	B35	Fig 3	160	180	340	-	100	165	372	637	296	64	115	28	61	89
	3LS 40-200/7.5	132S	B35	Fig 3	160	180	340	-	100	165	372	637	296	64	115	28	67	95
	3LS 40-200/11.0	160M	B35	Fig 4	160	180	340	42	100	198	488	786	296	107	115	42	110	152
50 mm x 65 mm	3LS 50-125/2.2	90L	B5	Fig 1	132	160	292	-	100	130	279	489	254	28	125	20	23	43
	3LS 50-125/3.0	100L	B35	Fig 3	132	160	292	-	100	142	316	558	254	38	125	20	33	53
	3LS 50-125/4.0	112M	B35	Fig 3	132	160	292	-	100	142	333	575	254	57	125	20	42	62
	3LS 50-160/5.5	132S	B35	Fig 3	160	180	340	-	100	165	372	637	296	64	125	29	61	90
	3LS 50-160/7.5	132S	B35	Fig 3	160	180	340	-	100	165	372	637	296	64	125	29	67	96
	3LS 50-200/9.2	132L	B35	Fig 3	160	200	360	-	100	165	410	675	296	64	125	29	74	103
	3LS 50-200/11.0	160M	B35	Fig 4	160	200	360	42	100	198	488	786	296	107	125	42	110	152
65 mm x 80 mm	3LS 65-125/4.0	112M	B35	Fig 2	160	180	340	-	100	142	333	575	254	57	145	26	42	68
	3LS 65-125/5.5	132S	B35	Fig 3	160	180	340	-	100	165	372	637	254	85	145	28	61	89
	3LS 65-125/7.5	132S	B35	Fig 3	160	180	340	-	100	165	372	637	254	85	145	29	67	96
	3LS 65-160/9.2	132M	B35	Fig 3	160	200	360	-	100	165	410	675	296	64	145	30	74	104
	3LS 65-160/11.0	160M	B35	Fig 4	160	200	360	42	100	198	488	786	296	107	145	40	110	150
	3LS 65-160/15.0	160M	B35	Fig 4	160	200	360	42	100	198	488	786	296	107	145	42	115	157
	3LS 65-200/15.0	160M	B35	Fig 3	180	225	405	-	100	208	488	696	296	107	145	30	115	145
	3LS 65-200/18.5	160L	B35	Fig 3	180	225	405	-	100	208	532	840	296	107	145	30	136	166
	3LS 65-200/22	180M	B35	Fig 5	180	225	405	-	100	208	554	862	296	127	145	30	172	202
	3LS 65-250/30	200L	B35	Fig 5	200	250	450	-	100	208	657	965	400	100	150	70	245	315
80 mm x 100 mm	3LS 80-160/11	160M	B35	Fig 3	180	225	405	-	125	208	488	821	350	80	150	52	110	162
	3LS 80-160/15	160M	B35	Fig 3	180	225	405	-	125	208	488	821	350	80	150	52	115	167
	3LS 80-160/18.5	160L	B35	Fig 3	180	225	405	-	125	208	532	865	350	80	150	53	136	189
	3LS 80-200/22	180M	B35	Fig 5	180	250	430	-	125	208	554	887	357	97	150	68	172	240
	3LS 80-200/30	200L	B35	Fig 6	180	250	430	20	125	208	657	990	400	100	150	72	245	317
	3LS 80-200/37	200L	B35	Fig 6	180	250	430	20	125	236	657	1018	400	100	150	73	260	333
	3LS 80-250/45	225S/M	B35	Fig 6	200	280	480	25	125	236	737	1098	450	148	150	88	411	499
3LS 80-250/55	250S/M	B35	Fig 7	200	280	480	80	125	248	783	1156	550	98	150	100	490	590	

Specifications subject to change without notice

Flanges
to DIN 2532

32, 40, 50
& 65 Ømm

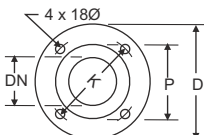

80 &
100 Ømm

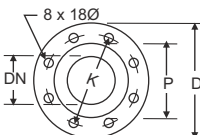

DN	32	40	50	65	80	100
P	75	80	95	115	120	135
K	100	110	125	145	160	180
D	140	150	165	185	200	225

- A** Typical with stamped casing
(i.e. all 32, 40 & 50mm & 65 -125/160/200)
- B** Typical with cast casing
(i.e. 65-250, & all 80)

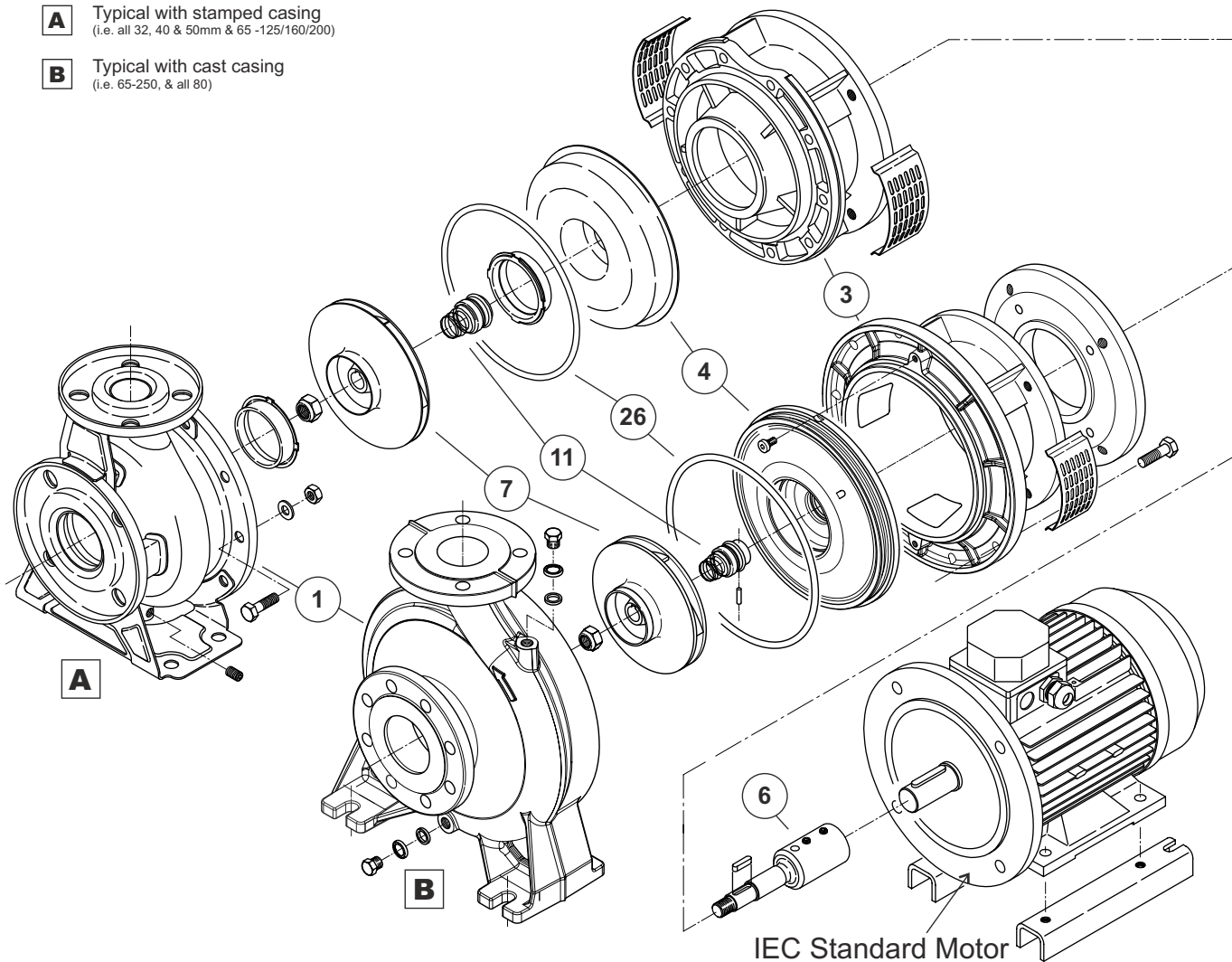

Note: Mounting and support feet varies between models.

Item	Description	Suits models	Materials
1	Casing	All 32, 40 & 50; 65-125/160/200	AISI 316L Stainless Steel - <i>stamped</i>
		65-250: All 80	AISI 316 Stainless Steel - <i>precision cast</i>
7	Impeller	All 32, 40 & 50	AISI 316L Stainless Steel - <i>stamped</i>
		All 65 & 80	AISI 316 Stainless Steel - <i>precision cast</i>
4	Casing Cover	32, 40 & 50; 65-125/160/200; 80-160	AISI 316L Stainless Steel - <i>stamped</i>
		65-250; 80-200/250	AISI 316 Stainless Steel - <i>precision cast</i>
26	O-ring (casing)	All models	Viton
11	Mechanical Seal	All models	SiC/SiC/Viton with anti rotation device for stationary seat.
6	Stub Shaft	All models	AISI 316 Stainless Steel (Up to 22 kW) Duplex Stainless Steel (30 to 55 kW)
3	Motor Bracket	All models	Cast Iron

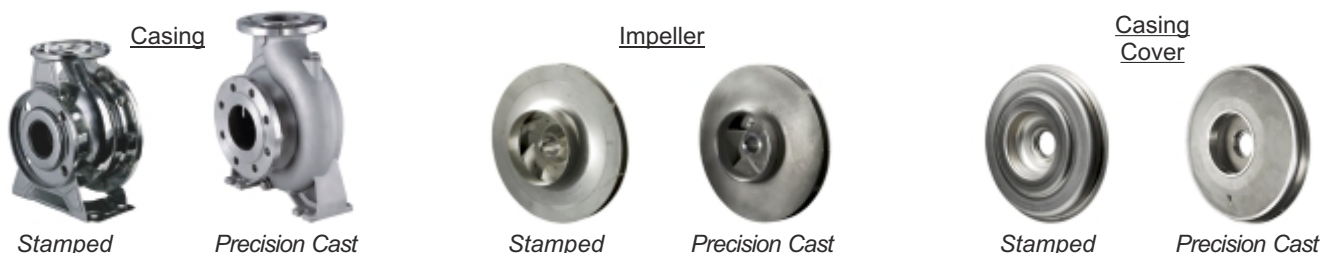

Specifications subject to change without notice