



EBARA

Looking ahead,
going beyond expectations

Ahead > *Beyond*

Japanese Technology since 1912

Vertical Multistage Pumps

Model **EVMS**

Sizes 1,3,5,10,15,20,32,45,64,90



Main product features

1



Innovative hydraulic solutions

Any motor ■ Anywhere

- Unique patented impeller design greatly reduces axial thrust
- Standard commercial motors can be fitted to all pump models due to the low thrust
- Long life of the motor bearings
- High pump efficiencies achieved

2



Energy saving

- High pump efficiency with MEI (minimum efficiency index) > 0.7
- IE3 motors fitted as standard
- Suitable for use with Variable Frequency Drives for further energy savings

3

Piping connection options

- Various pipe connections that meet many of the common market installation dimensions
- Able to select the most suitable connections for an application or replacement in an existing installation

Material	Round flange DIN <small>(incl. ANSI depending on models)</small>	Loose flange DIN <small>(incl. ANSI depending on models)</small>	Oval flange	Victaulic®	Clamp
AISI304 AISI316					
Cast SS ASTM CF8 ASTM CF8M					
Cast Iron					

4



Shaft seal solutions

- Shaft seal material:

B : Resin impregnated carbon graphite

Q₁: Sintered silicon carbide

Q₂: Silicon carbide with carbon graphite

E : EPDM

V : FPM (Viton)

- Conforming to EN12756 (ex DIN 24960)

5



Easy maintenance

- The cartridge shaft seal enables easy replacement without disassembling the motor bracket
- The spacer coupling allows for easy maintenance without having to lift heavy motors 5.5 kW & above

6

Smart plug solutions



Air ventilation plug



Priming & sensor plug



Fitting of commercial sensor



Drain / suction & discharge pressure

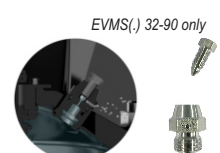

Combination priming & ventilation plug

EVMS() 32-90 only

Main product features

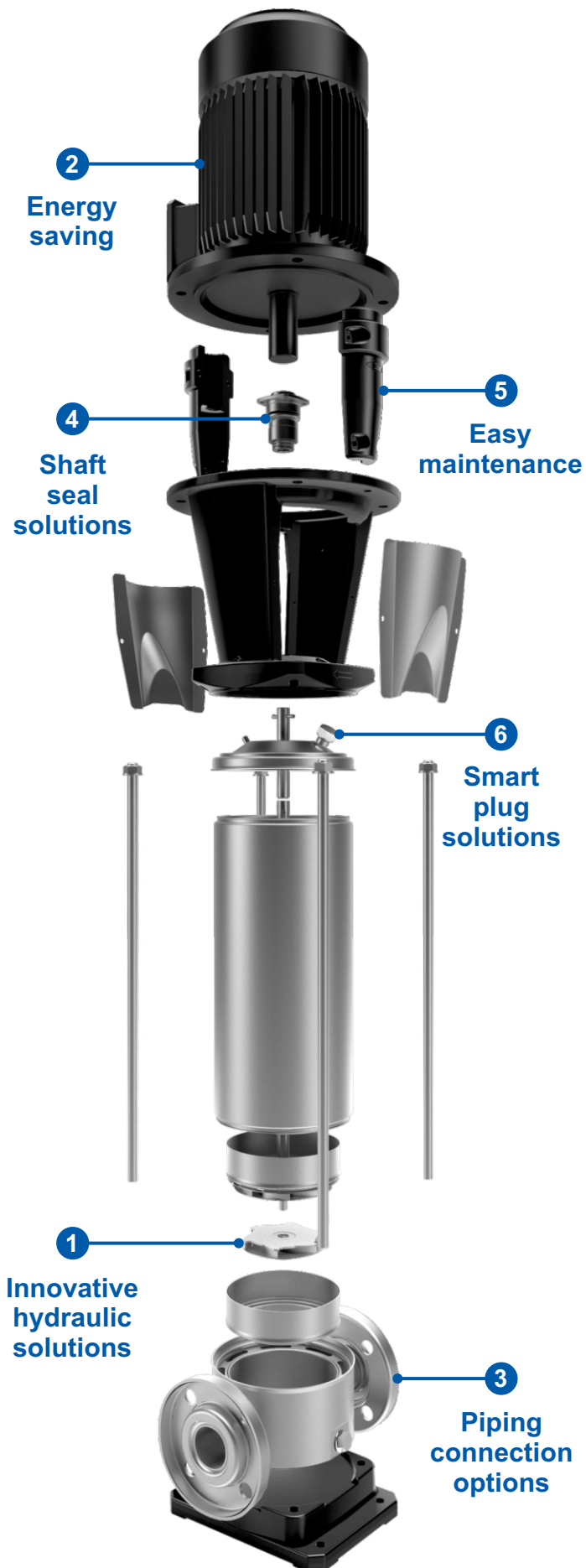

Typical construction

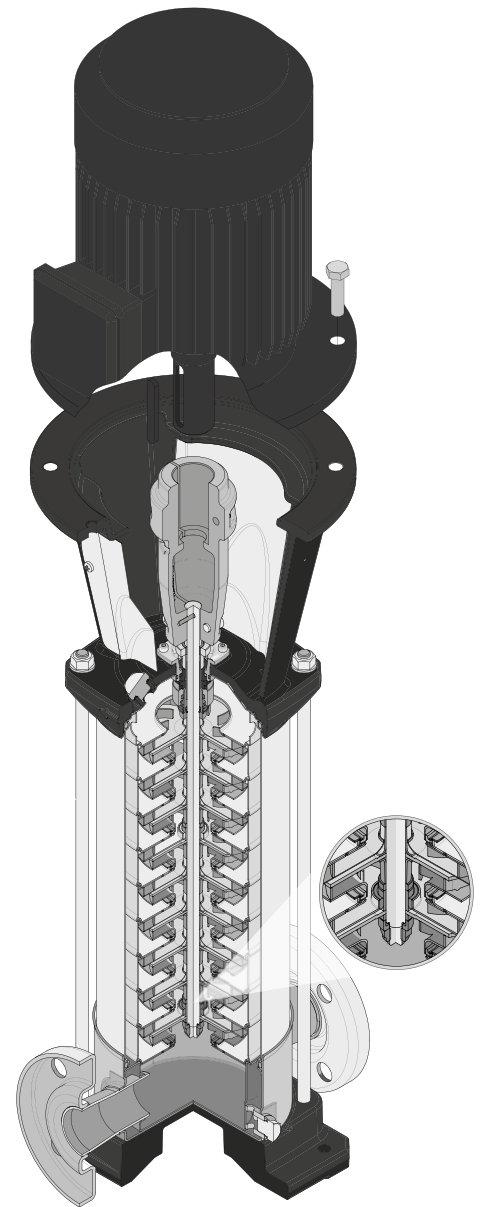

Note: models 37 kW and above have bearing in motor bracket

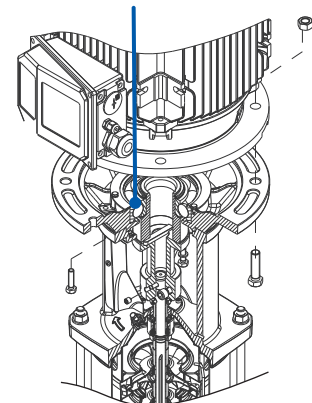

Performance range 50 Hz

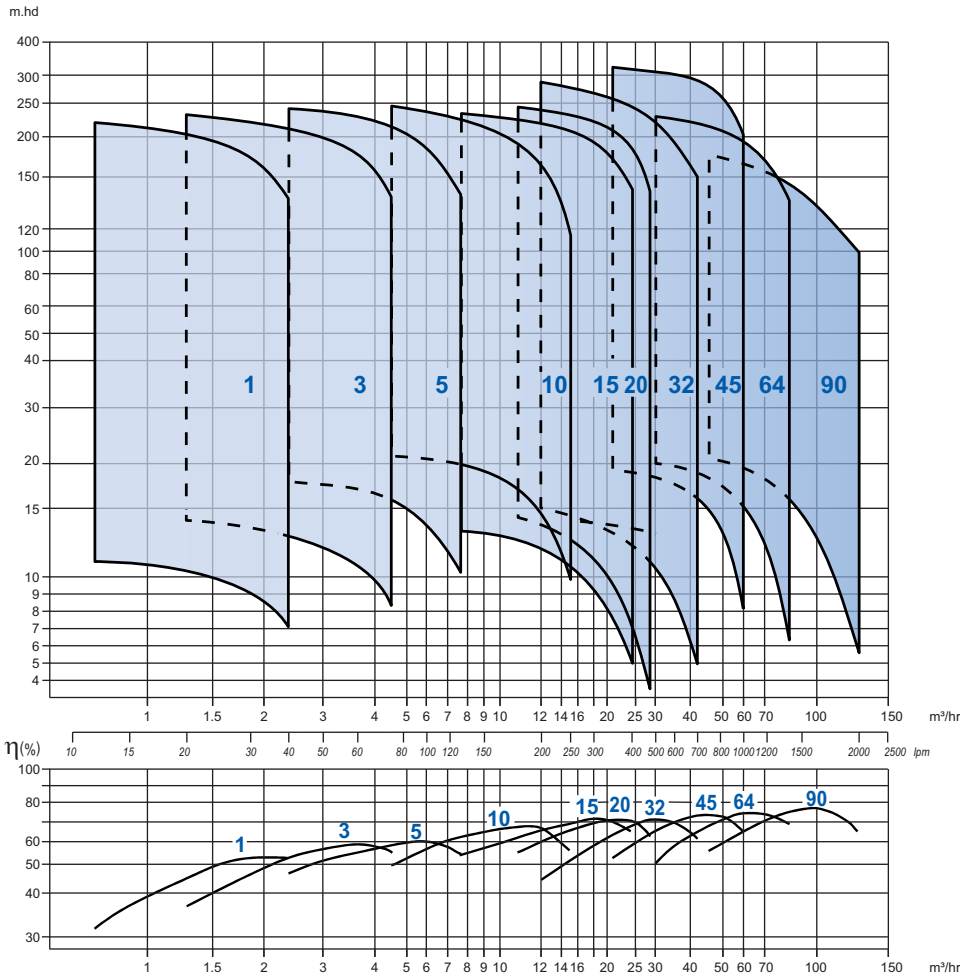

Minimum efficiency index (MEI)

Pump type	MEI
EVMS(.)1	> 0.70
EVMS(.)3	> 0.70
EVMS(.)5	> 0.70
EVMS(.)10	> 0.70
EVMS(.)15	> 0.70
EVMS(.)20	> 0.70
EVMS(.)32	> 0.70
EVMS(.)45	> 0.70
EVMS(.)64	> 0.70
EVMS(.)90	> 0.70

Performance EVMS(.) 1-3

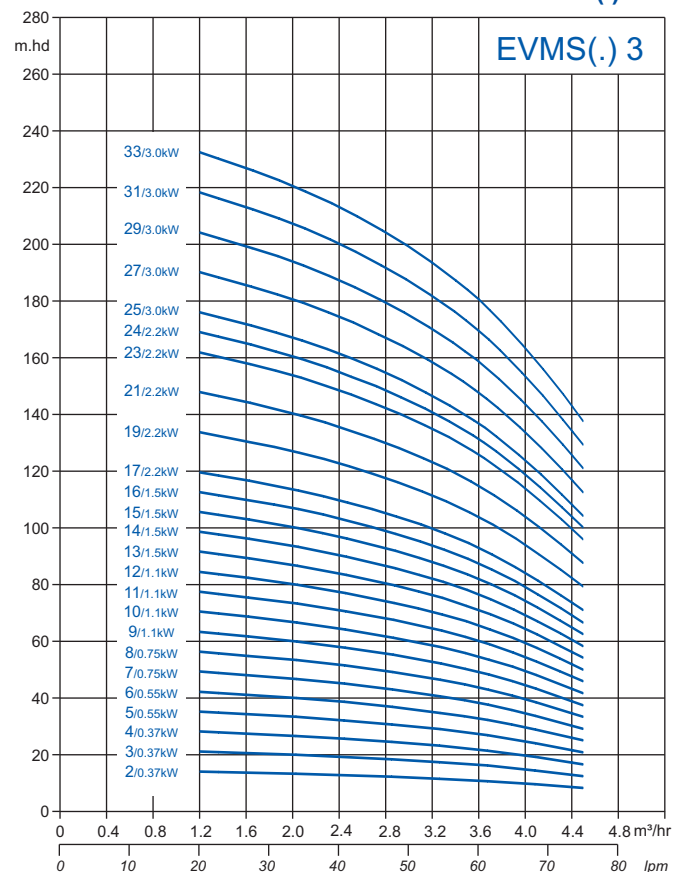
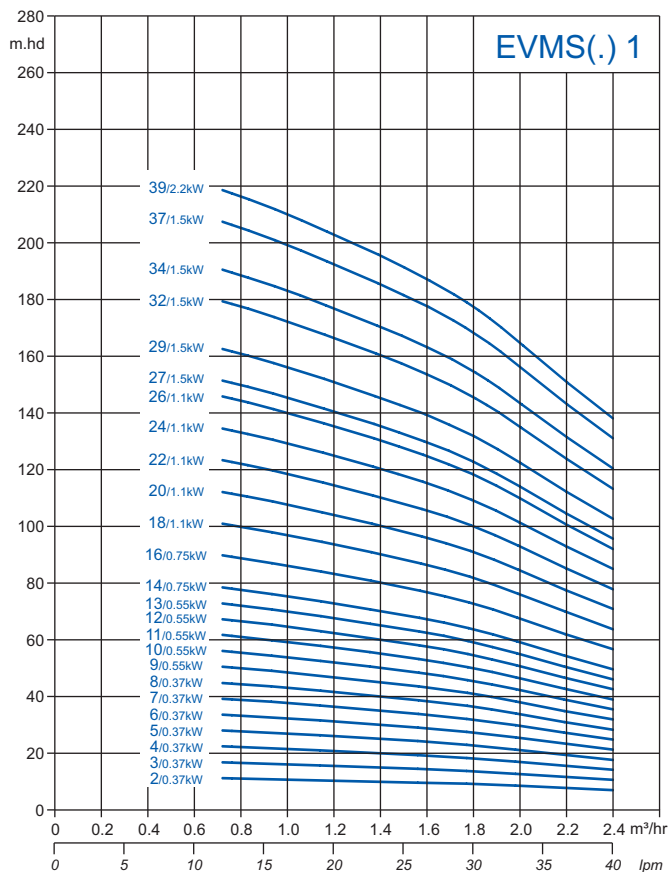

Performance

EVMS(.) 5-10-15-20

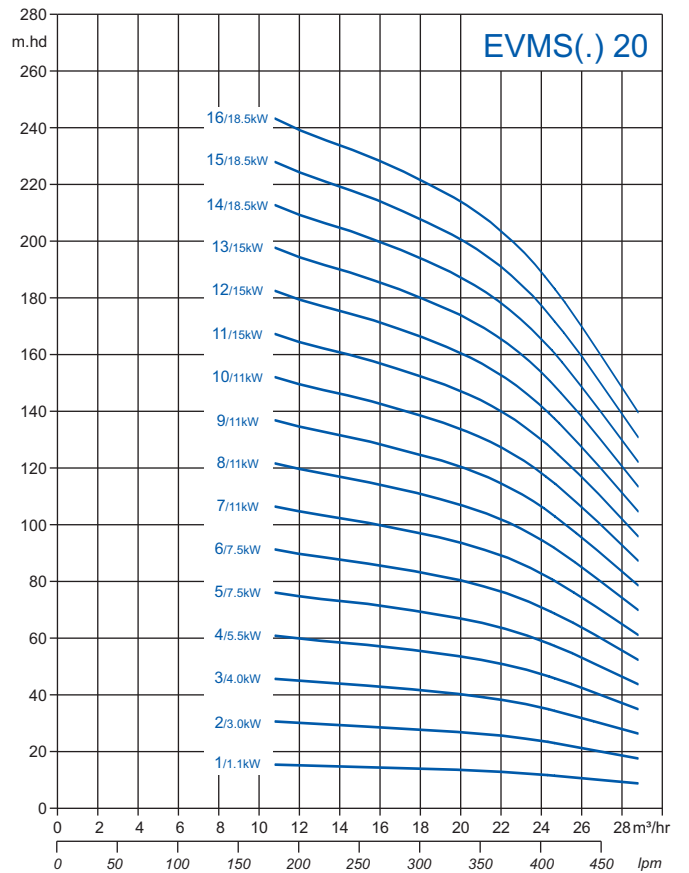
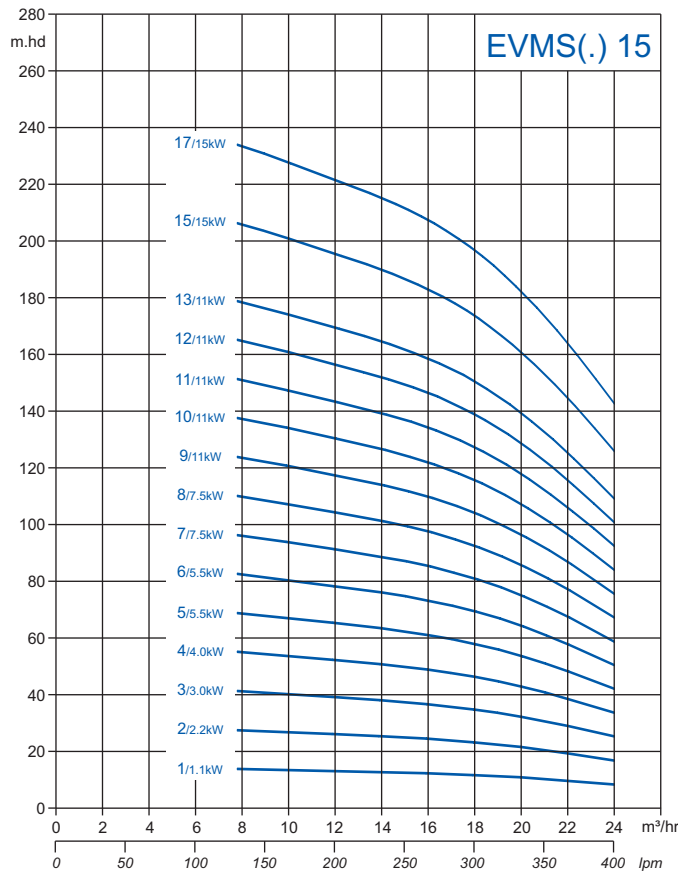
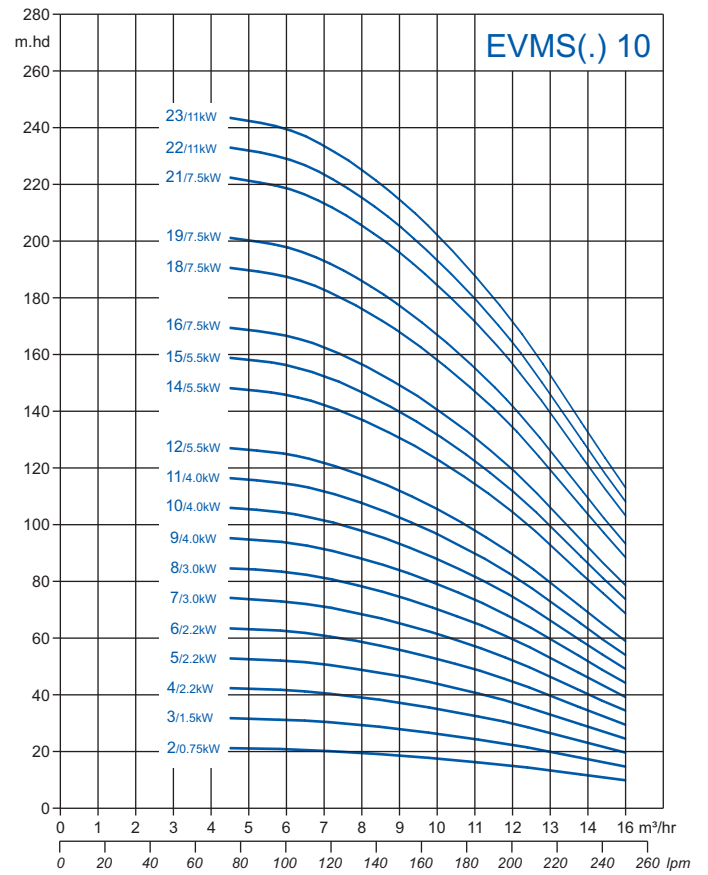
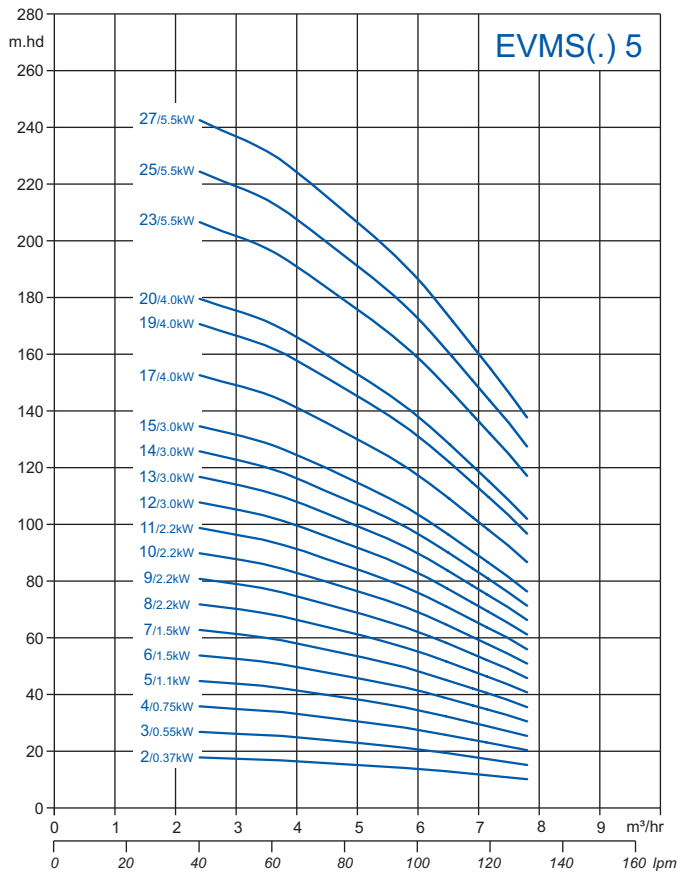

Performance

EVMS(.) 32-45-64-90

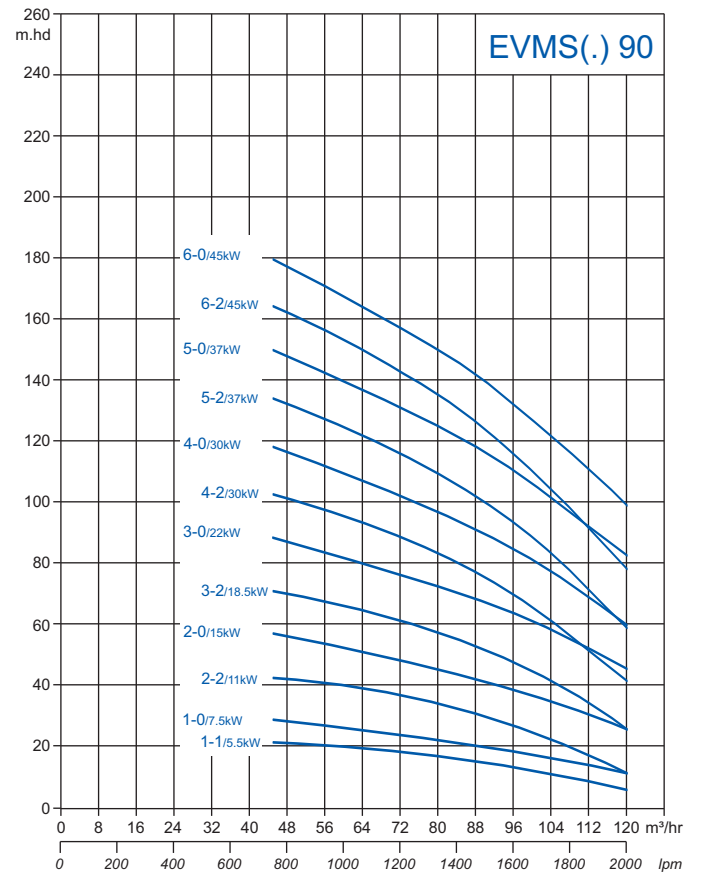
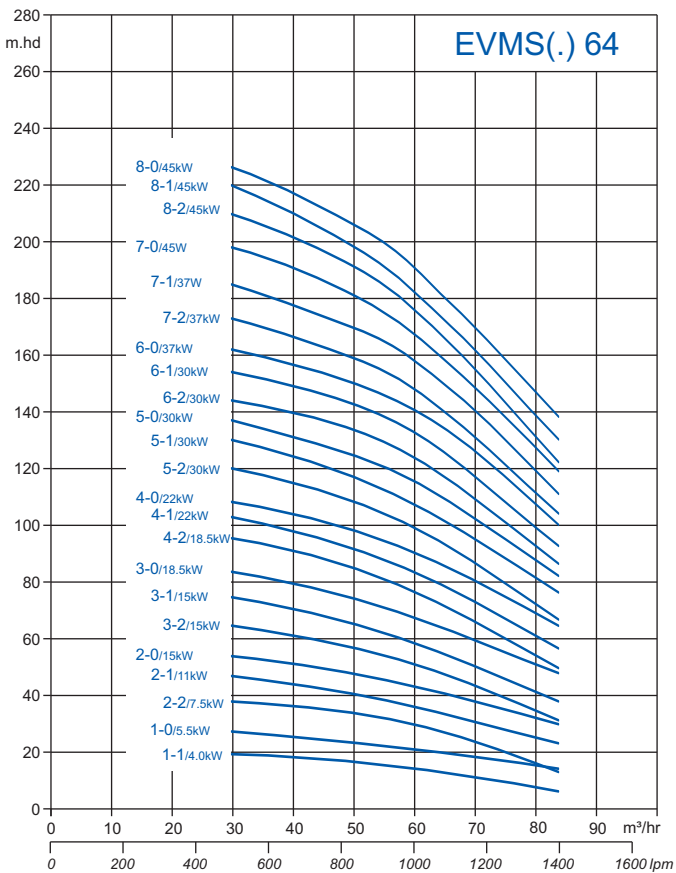
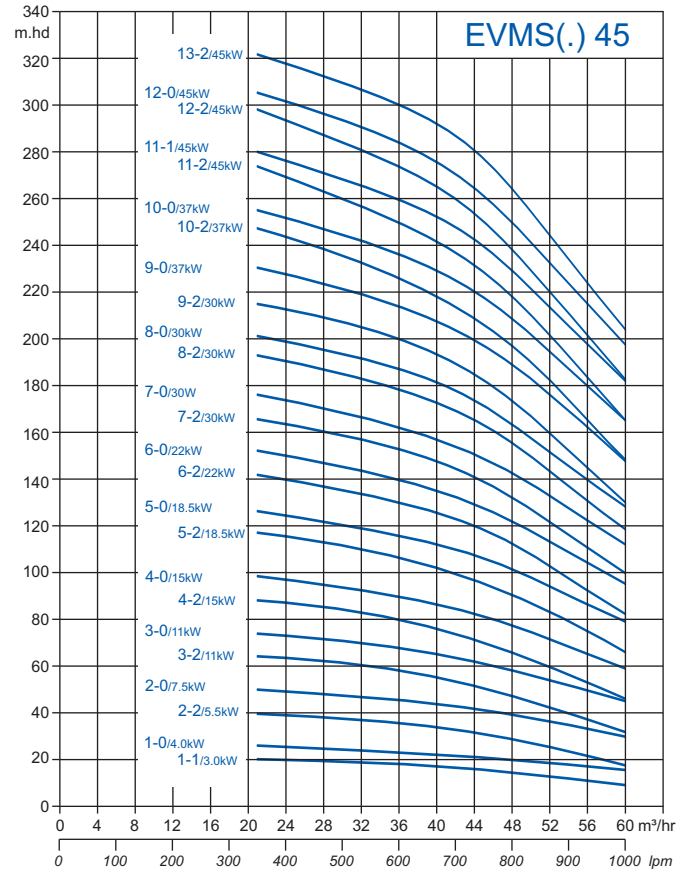
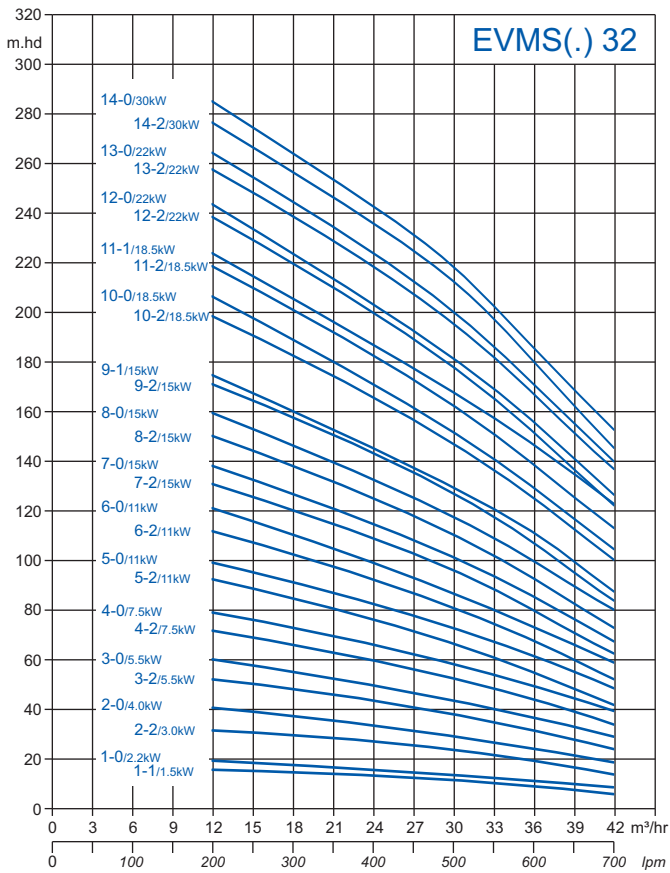

Your life ■ Our quality ■ Worldwide

Today as a group, Ebara consists of more than 100 companies around the world, with a workforce of more than 19,000 people. The huge scale of production and distribution is matched by a constant commitment to the research, development and design of new products; and the modern technologies for manufacturing them. Ebara products have gained a worldwide reputation for their technology and quality.

Ebara Corporation was founded in Japan in 1912 and has grown to become one of the world's leading pump companies, developing new and innovative pumps for over 100 years.

EVMS made in Italy

Established in Japan in 1912

Australian company started 2000.

As well as major manufacturing facilities in Japan, Ebara has production facilities in many other countries. This includes Italy with a most modern facility for the mass production of stamped stainless steel pumps. Utilising the latest manufacturing technologies, including a patented plasma stamping process, results in products of consistent high standards and quality.

For over 30 years Ebara pumps have been sold and used in Australia, satisfying many customers and gaining a reputation for their quality and reliability. Ebara Pumps Australia Pty Ltd was established in 2000 to better service the market with an increasing range of quality products. A strong nationwide network of dealers support the sales and service of our extensive range of products.

www.ebara.co.jp/en

Visit Ebara Corporation's website for more detail of their operation, product range and global network.

www.ebaraeurope.com

Visit the website of Ebara Pumps Europe for more detail on the large range of quality stainless steel pumps they produce.

www.ebara.com.au

Visit our website for more details on the range of pumps we stock and support, and our dealer network.

Specifications subject to change without notice

23/05

Dealer



EBARA PUMPS AUSTRALIA PTY. LTD

7 Holloway Drive
Bayswater, Vic. 3153
Ph: 03 9761 3033

ACN 090 963 572
ABN 81 090 963 572

sales.epa@ebara.com

www.ebara.com.au