

### Robust and reliable grinding



Cloth



Match



Panty hose



Vinyl

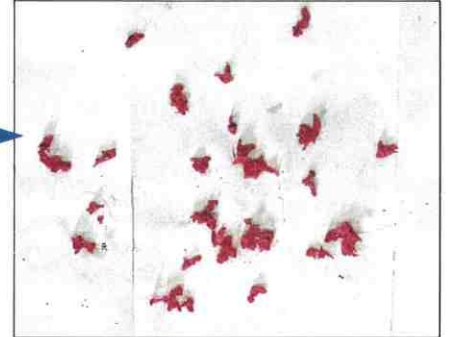

Balloon

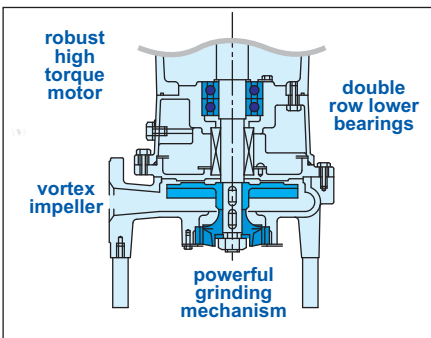

Carton



Straw

unit: mm

Made of hardened 440C stainless steel, the robust & reliable grinding components finely chop up foreign matter\* that may be found in sewage & grey waste water, and is combined with a vortex impeller for clog free operation.

\* not suitable for waste water containing metal, sand, stones or other hard and/or abrasive objects.

Suitable applications include:-

- Domestic sewage
- Small scale pressure sewage systems
- Grey wastewater containing soft solids i.e household, bathroom or kitchen waste